

Film Capacitors – Power Factor Correction

DeltaCap AKMJYS series capacitors

Series/Type: **AKMJYS series**
Date: Oct 10, 2021
Version: 01

Construction

- Dielectric: Polypropylene film
- Resin filling: Non-PCB, biodegradable soft resin dry type
- Wave cutting technology.
- Cylindrical aluminium can with stud and aluminium cover
- Provided with built-in discharge resistances

Features

- Three-phase delta connected,
- Provided with discharge resistances
- Double safety system:
 - Overpressure disconnecter,
 - Self healing technology
- Naturally air cooled (or forced air cooling)
- Indoor mounting

Typical applications

- For Power Factor Correction
 - Filtering out harmonic wave
 - Improve the quality of power supply
 - Improve the power factor

Terminals

- Screw terminals or Clip terminals

Mounting

- Threaded stud at bottom of can
(max. torque for M12 = 10 Nm / torque for M16 = 12 Nm)

Film Capacitors – Power Factor Correction

DeltaCap AKMJYS series capacitors

AKMJYS series

Technical data and specifications

Characteristics	
Rated capacitance C_R	According to specification table
Tolerance	-5% ~ +10%
Connection	D (Delta)
Rated voltage V_R	According to specification table
Rated frequency f_R	50 and 60 Hz
Output	According to specification table
Rated current I_R	According to specification table

Maximum ratings

V_{max}	$V_R + 10\%$ (up to 8 h daily) / $V_R + 15\%$ (up to 30 min daily) / $V_R + 20\%$ (up to 5 min daily) / $V_R + 30\%$ (up to 1 min daily)
I_{max}	Up to $2.5 \cdot I_R$ (A) (including combined effects of harmonics, overvoltages and capacitance tolerance)
I_S	Up to $200 \cdot I_R$ (A)

Test data

U_{TT}	$2.15 \times U_N$, during 10 s
U_{TC}	$(2 \times U_N) + 2000$ V AC or 3000V AC, during 10 s
* $\tan \delta$ (100 Hz)	$\leq 2.0 \times 10^{-3}$

Climatic category -40/D

T_{min}	-40 °C
T_{max}	+55 °C
Humidity	Av. rel. < 95%
Maximum altitude	4000 m

Mean life expectancy

t_{LD}	Up to 135 000 hours at temperature class -40/D Up to 150 000 hours at temperature class -40/C
----------	--

Max. 5000 switchings per year acc. to IEC 60831.1/2-2014

Film Capacitors – Power Factor Correction

DeltaCap AKMJYS series capacitors

AKMJYS series

Design data	
Dimensions (ϕ D x H)	According to specification table
Impregnation	Non PCB, resin filling: soft polyurethane resin dry type
Fixing	Threaded bolt M12x16 or M16x25
Max. torque (Al can stud)	M12: 10 Nm / M16: 12 Nm
Mounting position	Only in the upright position See "Maintenance and Installation Manual" for further details. Horizontal mounting with additional head support possible

Terminals	
Protection degree	IP20
Max.torque	6Nm
Terminal cross section	50mm ²
Maximum terminal current	100 A
Creepage distance (min)	≥24 mm
Clearance (min)	≥23 mm

Safety	
Mechanical safety	Overpressure disconnecter
Max. short circuit current	(AFC: 10 kA according UL 810 standard)
Discharge resistor time	≤ 180 s to 75 V or less (IEC 60831)

Reference standards

IEC 60831–1/2-2014 GB/T 12747.1/2-2017

Film Capacitors – Power Factor Correction

DeltaCap AKMJYS series capacitors

AKMJYS series

Type of terminals



Type: L
Screw type

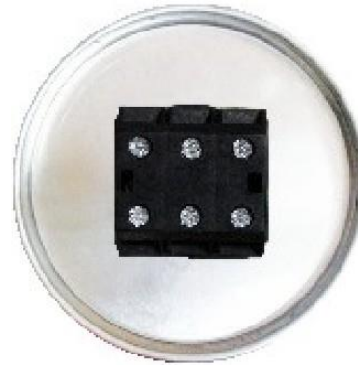

Type: K
Clip type

Type of aluminium can



Type: A
Normal aluminum can



Type: B
Pressure tank aluminum can





Type: C
Slot rolling aluminum can

Label design

 Power Quality Solutions
 DeltaCap™
 AKMJYS-L-A-0.48-30-3
 $138.2 \pm F_i \Delta$; $\pm -5\% \sim +10\%$ SH

U_N	$Q_N/50\text{Hz}$	$Q_N/60\text{Hz}$
480V~	30.00kvar	36.00kvar
440V~	25.21kvar	30.25kvar
415V~	22.43kvar	26.91kvar

 $U_i=3/-K_v$ IEC 60831-1-2014
 -40/D  IEC 60831-2-2014
 Protected 10K AFC Non PCB
 Overpressure disconnecter
 Discharge before handling
 Made by Universal October 10 2021

Note: parameter marked in “  ” is variable

Dimension drawing

AKMJYS-L-A

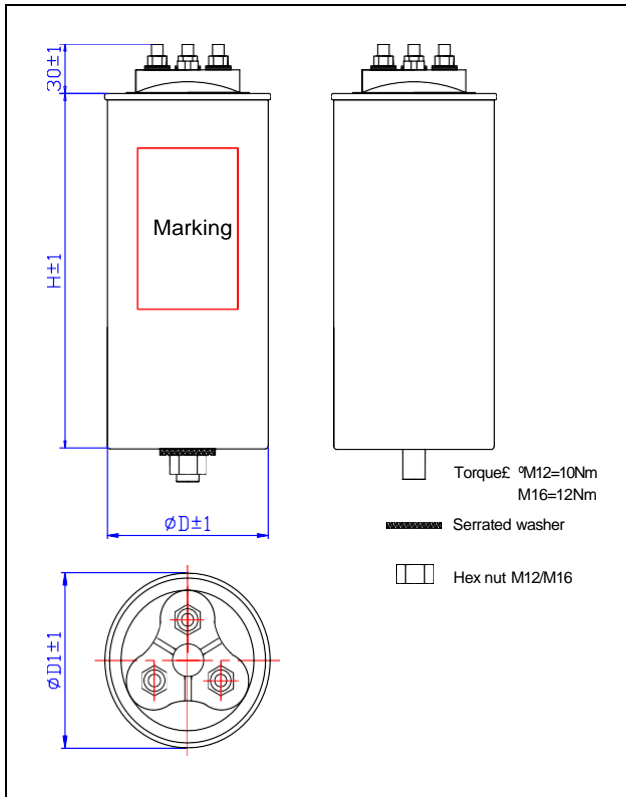

AKMJYS-K-A

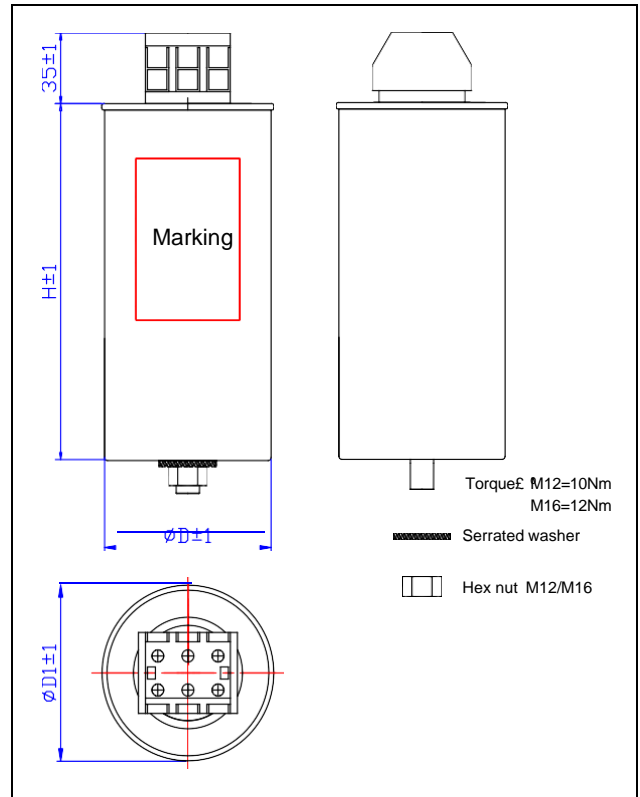

AKMJYS-L-B

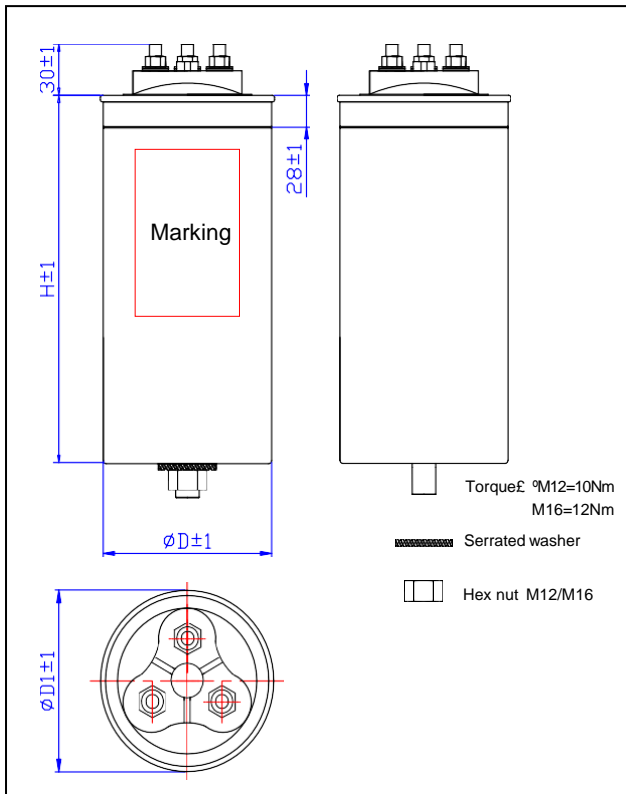

AKMJYS-K-B

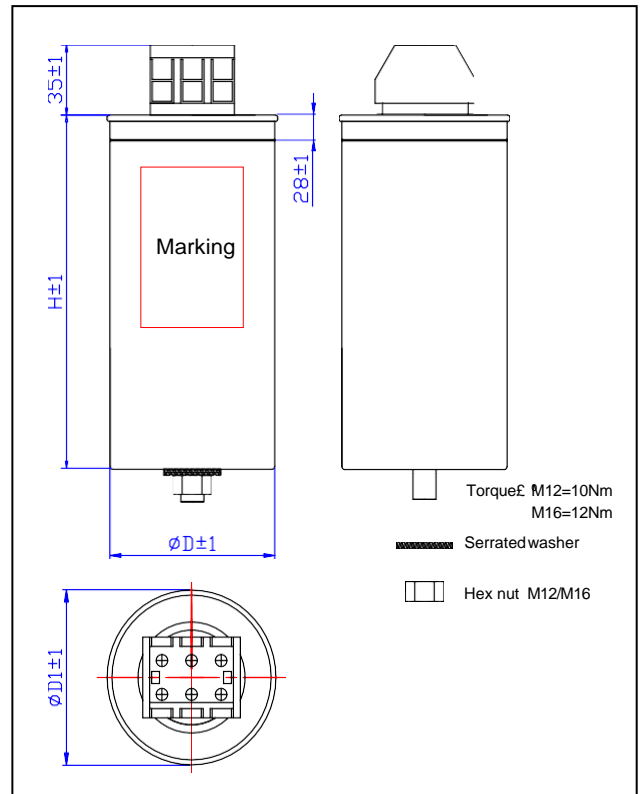

Film Capacitors – Power Factor Correction

DeltaCap AKMJYS series capacitors

AKMJYS series

AKMJYS-L-C

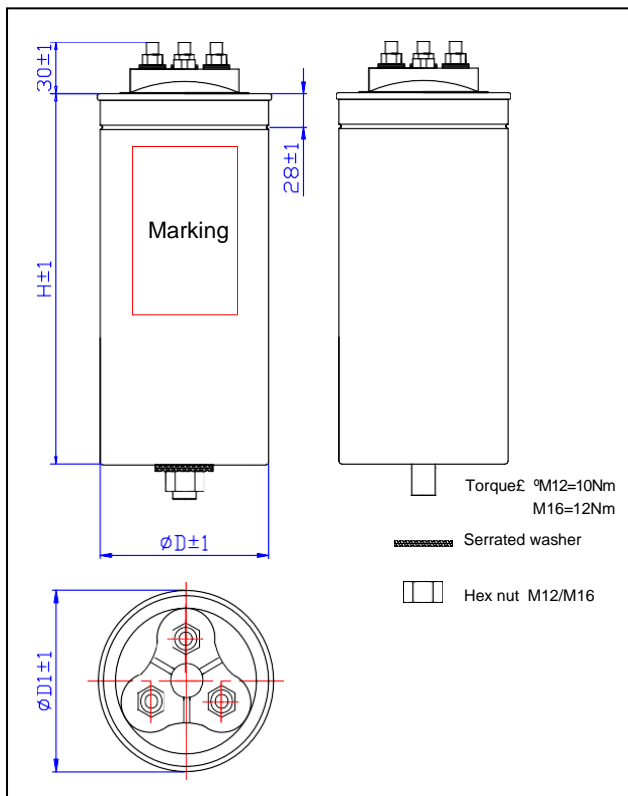

AKMJYS-K-C

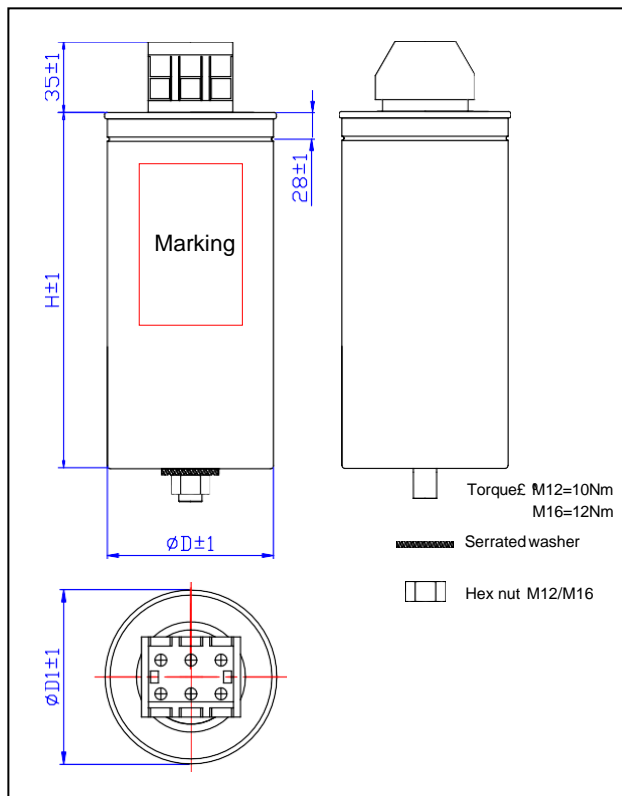

Specification table

Part number	50Hz		60Hz		C _R µF	Dimension (mm)			Bolt of the bottom	Packing unit pcs
	Output kvar	I _R A	Output kvar	I _R A		ΦD	ΦD1	H		
Rated voltage 450 V AC, 50/60 Hz, delta connection										
AKMJYS-X-X-0.45-5-3	5.0	6.4	6.0	7.7	26.2×3	65	68	160	M12×16	10
AKMJYS-X-X-0.45-10-3	10.0	12.9	12.0	15.4	52.4×3	76	79	235	M12×16	6
AKMJYS-X-X-0.45-15-3	15.0	19.3	18.0	23.1	78.6×3	86	89	235	M12×16	6
AKMJYS-X-X-0.45-20-3	20.0	25.7	24.0	30.8	104.8×3	96	99	278	M12×16	4
AKMJYS-X-X-0.45-25-3	25.0	32.1	30.0	38.5	131.0×3	106	106	278	M16×25	4
AKMJYS-X-X-0.45-30-3	30.0	38.5	36.0	46.2	157.2×3	116	119	278	M16×25	4

Film Capacitors – Power Factor Correction
DeltaCap AKMJYS series capacitors
AKMJYS series

Part number	50Hz		50Hz		C _R	Dimension (mm)			Bolt of the bottom	Packing unit pcs
	Output kvar	I _R A	Output kvar	I _R A	μF	ΦD	ΦD1	H		
AKMJYS-X-X-0.45-33.4-3	33.4	42.9	40.1	51.5	175.0×3	126	129	278	M16×25	4
AKMJYS-X-X-0.45-35-3	35.0	44.9	42.0	53.9	183.4×3	126	129	278	M16×25	4
AKMJYS-X-X-0.45-40-3	40.0	51.4	48.0	61.6	209.6×3	136	139	278	M16×25	4
Rated voltage 480 V AC, 50/60 Hz, delta connection										
AKMJYS-X-X-0.48-5-3	5.0	6.0	6.0	7.2	23.0×3	65	68	160	M12×16	10
AKMJYS-X-X-0.48-10-3	10.0	12.0	12.0	14.5	46.0×3	76	79	235	M12×16	6
AKMJYS-X-X-0.48-15-3	15.0	18.0	18.0	21.7	69.0×3	86	89	235	M12×16	6
AKMJYS-X-X-0.48-20-3	20.0	24.0	24.0	28.9	92.1×3	96	99	278	M12×16	4
AKMJYS-X-X-0.48-25-3	25.0	30.0	30.0	36.0	115.2×3	106	106	278	M16×25	4
AKMJYS-X-X-0.48-30-3	30.0	36.0	36.0	43.3	138.2×3	116	119	278	M16×25	4
AKMJYS-X-X-0.48-33.4-3	33.4	40.2	40.1	48.3	153.8×3	126	129	278	M16×25	4
AKMJYS-X-X-0.48-35-3	35.0	42.1	42.0	50.5	161.2×3	126	129	278	M16×25	4
AKMJYS-X-X-0.48-40-3	40.0	48.2	48.0	57.7	184.2×3	136	139	278	M16×25	4
Rated voltage 525 V AC, 50/60 Hz, delta connection										
AKMJYS-X-X-0.525-5-3	5.0	5.5	6.0	6.6	19.3×3	65	68	160	M12×16	10
AKMJYS-X-X-0.525-10-3	10.0	11.0	12.0	13.2	38.5×3	76	79	235	M12×16	6
AKMJYS-X-X-0.525-15-3	15.0	16.5	18.0	19.8	57.7×3	86	89	235	M12×16	6
AKMJYS-X-X-0.525-20-3	20.0	22.0	24.0	26.4	77.0×3	96	99	278	M12×16	4
AKMJYS-X-X-0.525-25-3	25.0	27.5	30.0	33.0	96.3×3	106	106	278	M16×25	4
AKMJYS-X-X-0.525-30-3	30.0	33.0	36.0	39.6	115.5×3	116	119	278	M16×25	4

Film Capacitors – Power Factor Correction

DeltaCap AKMJYS series capacitors

AKMJYS series

Part number	50Hz		60Hz		C _R	Dimension (mm)			Bolt of the bottom	Packing unit pcs
	Output kvar	I _R A	Output kvar	I _R A	μF	ΦD	ΦD1	H		
AKMJYS-X-X-0.525-33.4-3	33.4	36.8	40.1	44.1	128.6×3	126	129	278	M16×25	4
AKMJYS-X-X-0.525-35-3	35.0	38.5	42.0	46.2	134.8×3	126	129	278	M16×25	4
AKMJYS-X-X-0.525-40-3	40.0	44.0	48.0	52.8	154.0×3	136	139	278	M16×25	4

Part number system

AKMYS - X - X - 0.48 - 30 - 3

① ② ③ ④ ⑤ ⑥

① -- Series code

② -- Type of terminals: L -- Screw type

 K -- Clip type

③ -- Type of aluminium can: A -- Normal aluminum can

 B -- Pressure tank aluminum can

 C -- Slot rolling aluminum can

④ -- Rated voltage of capacitor

⑤ -- Rated capacitance of capacitor

⑥ -- Compensation mode 3 - Three-phase (Δ) : 1 - Single-phase

Note:

If it is the single-phase capacitor with the same voltage and capacity, capacitor without middle terminal, its current is 1.732 times rated current, and other parameters are the same

Cautions and warnings

Film Capacitors – Power Factor Correction

DeltaCap AKMJYS series capacitors

AKMJYS series

- In case of dents of more than 1 mm depth or any other mechanical damage, capacitors must not be used at all.
- This applies also in cases of oil leakages.
- To ensure the full functionality of the overpressure disconnecter, elastic elements must not be hindered and a minimum space of 12 mm has to be kept above each capacitor.
- Do not handle the capacitor before it is discharged.
- Resonance cases must be avoided by appropriate application design in any case.
- Handle capacitors carefully, because they may still be charged even after disconnection due to faulty discharging devices.
- Protect the capacitor properly against over current and short circuit.
- Failure to follow cautions may result, worst case, in premature failures, bursting and fire.

Service life expectancy

Electrical components do not have an unlimited service life expectancy; this applies to self-healing capacitors too. The maximum service life expectancy may vary depending on the application the capacitor is used in.

Safety

Electrical or mechanical misapplication of capacitors may be hazardous. Personal injury or property damage may result from bursting of the capacitor or from expulsion of oil or melted material due to mechanical disruption of the capacitor.

- Ensure good, effective grounding for capacitor enclosures.
- Provide means of disconnecting and insulating a faulty component/bank.
- The terminals of capacitors, connected bus bars and cables as well as other devices may also be energized.
- Follow good engineering practice.

Thermal load/over-temperature

After installation of the capacitor it is necessary to verify that maximum hot-spot temperature is not exceeded at extreme service conditions.

Overpressure disconnecter

To ensure full functionality of an overpressure disconnecter, the following must be observed:

1. The elastic elements must not be hindered, i.e.
 - Connecting lines must be flexible leads (cables).
 - There must be sufficient space (min. 12 mm) for expansion above the connections. This will enable a longitudinal extension of the can to secure the overpressure disconnecter work.
 - Folding beads must not be retained by clamps.
2. The maximum allowed fault current of 10000 A in accordance with UL 810 standard must be assured by the application.
3. Stress parameters of the capacitor must be within the IEC60831 specification.

Overcurrent and short circuit protection

Film Capacitors – Power Factor Correction

DeltaCap AKMJYS series capacitors

AKMJYS series

- Use HRC fuses or MCCBs for short circuit protection. Short circuit protection and connecting cables should be selected so that 1.5 times the rated capacitor current can be permanently handled.
- HRC fuses do not protect a capacitor against overload – they are only for short circuit protection.
- The HRC fuse rating should be 1.6 to 1.8 times rated capacitor current.
- Do not use HRC fuses to switch capacitors (risk of arcing).
- Use thermal magnetic over current relays for overload protection.

Resonance cases

Resonance cases must be avoided by appropriate application design in any case. Maximum total RMS capacitor current (incl. fundamental harmonic current) specified in technical data must not be exceeded.

Re-switching vs. phase-opposition

In case of voltage interruption, a sufficient discharge time has to be ensured to avoid phase-opposition and resulting high inrush currents.

Vibration resistance

The resistance to vibration of capacitors corresponds to IEC 60831, part 2–6.

Max. test conditions:

Test duration	6 h*
Frequency range 1	10 ... 55 Hz*
Displacement amplitude	0.75 mm*

These figures apply to the capacitor alone. Because the fixing and the terminals may influence the

vibration properties, it is necessary to check stability when a capacitor is built in and exposed to vibration. Irrespective of this, you are advised not to locate capacitors where vibration amplitude reaches the maximum in strongly vibrating equipment.

Mechanical protection

The capacitor has to be installed in a way that mechanical damages and dents in the aluminum can are avoided.

Grounding

The threaded bottom stud of the capacitor has to be used for grounding. In case grounding is done via metal chassis that the capacitor is mounted to, the layer of varnish beneath the washer and nut should be removed. The maximum tightening torque is 10 Nm.

Maintenance

- Check tightness of the connections/terminals periodically.
- Take current reading twice a year and compare with nominal current. Use a harmonic analyser or true effective RMS-meter.
- In case of current above the nominal current check your application for modifications.
- If a significant increase in the amount of non-linear loads has been detected, then a consultant has to be called in for a harmonic study.
- In case of the presence of harmonics installation of a de-tuned capacitor bank (reactors) must be considered.
- Check the discharge resistors/reactors and in case of doubt, check their function:
 - (1) Power the capacitor up and down.
 - (2) After ≤ 180 seconds the voltage between the terminals must decline to less than 75 V.
- Check the temperature of capacitors directly after operation for a longer period, but make sure that the capacitors have been switched off. In case of excessive temperature of individual capacitors, it is recommended to replace these capacitors, as this should be an indication for loss factor increase, which is a sign for reaching end of life.

Storage and operating conditions

Do not use or store capacitors in corrosive atmosphere, especially where chloride gas, sulfide gas, acid, alkali, salt or the like are present. In dusty environments regular maintenance and cleaning especially of the terminals is required to avoid conductive path between phases and/or phases and ground.

